HOLIDAYS ON THE NET

OUR CALENDAR

Type of module	Using the Internet
Target group	14-17-year-old learners
Level	A2
Written by	Csibi Erzsébet, Hunya Márta

A kiadvány az Educatio Kht. kompetenciafejlesztő oktatási program kerettanterve alapján készült.

A kiadvány a Nemzeti Fejlesztési Terv Humánerőforrás-fejlesztési Operatív Program 3.1.1. központi program (Pedagógusok és oktatási szakértők felkészítése a kompetencia alapú képzés és oktatás feladataira) keretében készült, a sulinova oktatási programcsomag részeként létrejött tanulói információhordozó. A kiadvány sikeres használatához szükséges a teljes oktatási programcsomag ismerete és használata.

A teljes programcsomag elérhető: www.educatio.hu címen.

Szakmai vezető: Kuti Zsuzsa

Szakmai bizottság: Enyedi Ágnes, dr. Majorosi Anna, dr. Morvai Edit

Szakmai lektor: Sillár Barbara

Idegen nyelvi lektorok: Debbie Goretity, Doug Allan

Alkotószerkesztő: Sákovics Lília

Szakértő: Tartsayné Németh Nóra

Grafikai munka: Walton Promotion Kft.

Felelős szerkesztő: Burom Márton

©

Szerzők: Csibi Erzsébet, Csíky Anna, Fehér Judit, Hunya Márta, Prievara Tibor

Educatio Kht. 2008

Name:

Date:



TASK 1 - VALENTINE'S BATTLESHIP

■ Put or draw 6 hearts / sweets anywhere in the grid. Play the game in pairs for 5 minutes. Use the right vocabulary!

7							
6							
5							
4							
3							
2							
1							
	A	B	C	D	E	F	G

Do you have a heart in A1? / Is there a heart in A4? / Have you got anything in A7? / What about D2?	No, it's empty. / No, there is nothing. / Luckily not. Unfortunately, yes. / You sank it! / I lost it. / You did it.
Cross it out. How many hearts do you have left? /How many hearts have you collected? It's over. / Game over. / I have nothing left. / I have collected x hearts. You / I won. You / I lost.	

TASK 2 – LEARNING ABOUT ST VALENTINE

TASK 2 A - MATCHING

■ Put the right letter next to the corresponding number. You can get ideas from the text in Task 2 C.

1	rule	A	continue
2	volunteer	B	official rule
3	law	C	go away with no problem
4	priest	D	habit, regular activity
5	keep on ...ing	E	job at the church
6	bride and groom	F	lead, govern
7	whisper	G	do something of one's own free will
8	escape	H	say something in a very low voice
9	death penalty	I	capital punishment (the highest)
10	keep your spirits up	J	wife and husband at marriage ceremony
11	custom	K	someone else wins
12	be beaten	L	do not lose hope, be happy

TASK 2 B – TRUE OR FALSE?

■ Say if the following statements are true or false according to the text in Task 2 C.

	True √	False X	Don't know ?
1 Claudius II ruled the Roman Empire for less than two years (268 - 270).			?
2 Claudius did not let people get married.			
3 Valentine was a young man who wanted to get married.			
4 Valentine lived in a small room which he lit with candles.			
5 He was put in prison because he helped people get married			
6 When he was imprisoned, the young couple went with him.			
7 Valentine had a lot of young visitors in jail.			
8 The prison guard's daughter fell in love with Valentine			
9 Valentine's Day is about love and friendship.			
10 Sept 14 was the day when Valentine married the Guard's daughter.			

TASK 2 C – INTERVIEWING ST VALENTINE

■ Re-read the 'self-portrait' below with your partner and make questions to exploit the information. Underline the answers. Practice and act out the interview.

Q1 *Who are you and when did you live?*

Let me introduce myself. My name is Valentine. I lived in Rome during the third century. At that time, Rome was ruled by Claudius. I didn't like Emperor Claudius, and I wasn't the only one! A lot of people shared my feelings.

Q2 _____

Q3 _____

Claudius wanted to have a big army. He expected men to volunteer to join. Many men did not want to fight in wars. They did not want to leave their wives and families. So what happened? Claudius had a crazy idea. He thought that if men were not married, they would not mind joining the army. So Claudius decided not to allow any more marriages. Young people thought his new law was cruel. I certainly did not want to support that law!

Q4 _____

Q5 _____

Did I mention that I was a priest? One of my favourite activities was to marry couples. I kept on performing marriage ceremonies - secretly, of course. It was really quite exciting. Imagine a small candlelit room with only the bride and groom and myself. We used to whisper the words of the ceremony, listening all the while for the steps of soldiers.

Q6 _____

One night, we heard footsteps. It was frightening! Thank goodness the couple escaped in time. I was caught. I was put in prison and received the death penalty.

Q7 _____

I tried to stay cheerful. And do you know what? Wonderful things happened. Many young people came to the prison to visit me. They threw flowers and notes up to my window. They wanted me to know that they, too, believed in love.

Q8 _____

Q9 _____

One of these young people was the prison guard's daughter. Her father allowed her to visit me in the cell. We used to talk for hours. She helped me to keep my spirits up. She agreed that I did the right thing with the secret marriages. On the day when I was to die, I left my friend a little note thanking her for her friendship. I signed it, "Love from your Valentine."

Q10 _____

I believe that note started the custom of exchanging love messages on Valentine's Day. It was written on the day I died, February 14, 269 A.D. Now, every year on this day, people remember. But most importantly, they think about love and friendship. And when they think of Emperor Claudius, they remember how he tried to stand in the way of love, and they laugh - because they know that love can't be beaten!

Based on Isabel Perez's work

<http://www.isabelperez.com/St%20ValentineStory.htm>

TASK 3 – EVALUATION

■ Put the signs that you used in Task 2 B into the right columns. Then exchange the sheet with the classmate with whom you have worked.

	Me	My mate
I used the target language while playing the battleship game. Or: I could identify lots of words in the word game.		
I worked hard to learn about St Valentine.		
I played an equal part while acting out the interview.		

Our homework choice: _____

Happy Valentine's Day



How many words can you make out of **Happy Valentine's Day**?

- 1
- 2
- 3
- 4
- 5
- 6
- 7
- 8
- 9
- 10
- 11
- 12
- 13
- 14
- 15

Free Valentine's Day cliparts: <http://www.hellasmultimedia.com/webimages/valentine-htm/default.htm>

Did you find? Put the right words before their explanation.

1		Someone from another planet.
2		Very small.
3		A cat, a dog, or a goldfish.
4		A big mammal.
5		Give something for temporary use.
6		The opposite of like.
7		The opposite of early.
8		The opposite of sit.
9		Something to put food on.
10		A fruit.
11		A tragedy or a comedy.
12		Write on a keyboard.
13		Small money.
14		Jump forward, big step.
15		Make a picture.

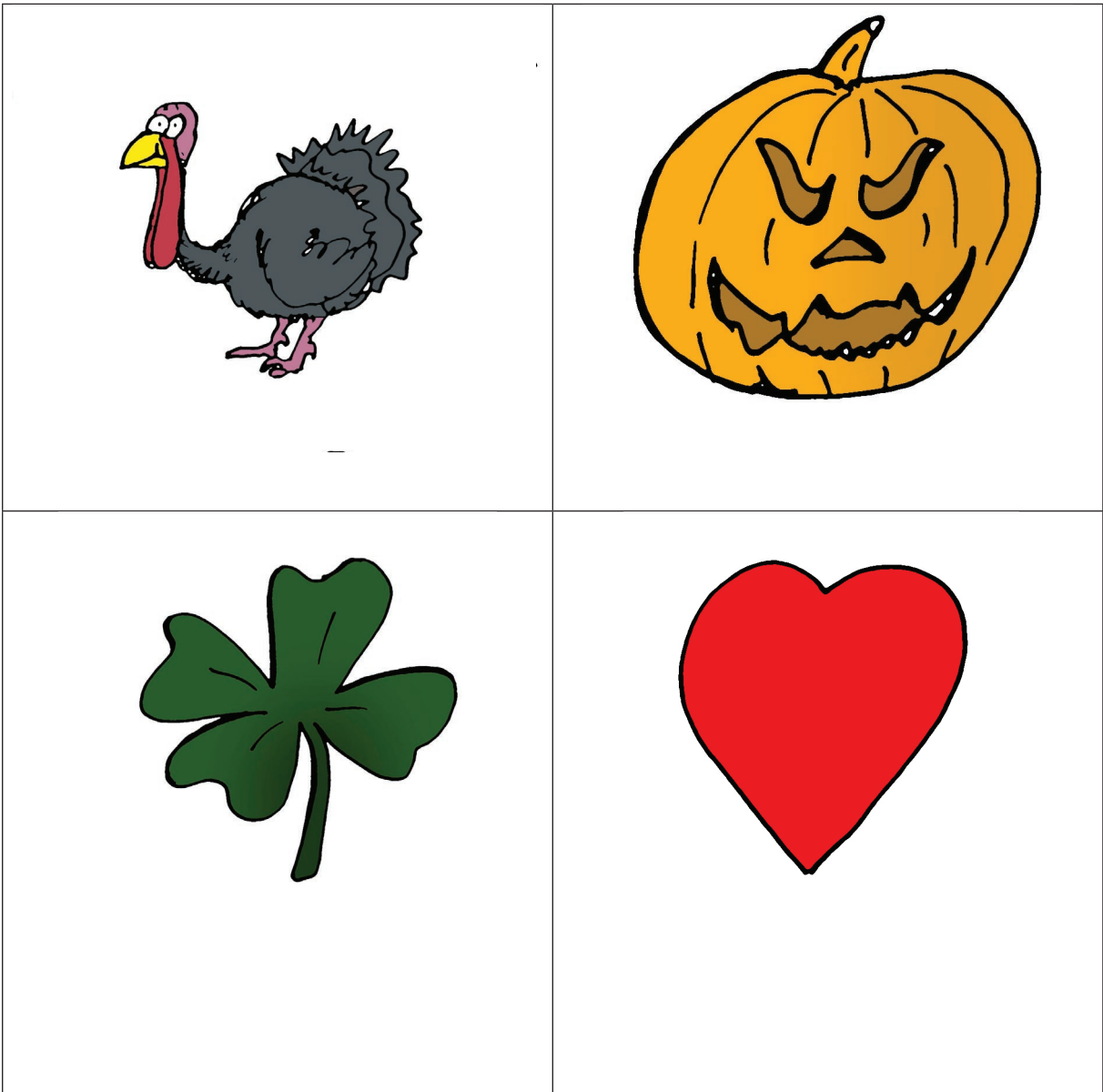

Name:

Date:



TASK 1 - FOOD AND LOVE

■ a) Circle all the food words in the love-poem below!

I love you more than apple-sauce, (A)	I love you more than lemonade,
Than peaches and a plum, (B)	And seven-layer cake,
Than chocolate hearts, (C)	Than lollipops,
And cherry tarts, (C)	And candy drops,
And berry bubble-gum (B)	And thick vanilla shake.

I love you more than marzipan,
 Than marmalade on toast;
 For I love pies
 Of any size,
 But I love you the most.

By: Jack Prelutsky

■ b) Put all the food names into categories.

Main dishes or part of them	
Sweets, candies	
Cakes	
Drinks	
Fruit	
Food for breakfast	

■ c) Write the corresponding taste under each picture!



sweet

salty/savoury

sour

hot/spicy

bitter

■ d) Which category does most of the food in the poem belong to?

Why? Because Love is but also can be

■ e) Find the rhyme formula of each verse. Put the right letters in the end of each line! It will help you to pronounce the words better.

■ f) Practise reading the poem in pairs; then act it out to the others.

TASK 2 - MATHS TRANSLATION

■ Translate the quotation: *“In the arithmetic of love, one plus one equals everything, and two minus one equals nothing.”*
(Mignon McLaughlin)



TASK 3 - PLANNING GROUP WORK

■ a) Write the dates and the names of the holidays under the pictures that symbolise them. Name the symbols as well.

		
	31 October	17 March
Thanksgiving		
		Clover (leaf)

17 March
31 October ✓
24 November

Halloween
St. Patrick's Day
Thanksgiving ✓

Clover (leaf) ✓
Turkey
Pumpkin

b) Our holiday is: _____

Roles and timing (you can put some tasks together or divide them according to the number of group members)

Job and tasks	Name:
Web Editor and Chief Editor: tries Netscape Composer (and teaches the others), helps the others, creates the Top 10 Links page, links the sub-pages to each other.	
Game Editor: collects 5 URLs of very good online games, creates their page, keeps an eye on group work and time.	
Resource Editor: collects 3 URLs of good resources on the history of the day, creates its page, takes care of correct references to original resources.	
Picture Editor: collects URLs of 10 free images, creates their page.	
Fun Editor: collects URLs of some related pieces of music, jokes or other extras, creates their page.	

Other arrangements and agreements:

TASK 4 – SELF-EVALUATION

■ a) Put a \checkmark where applicable.

	Very good	Satisfactory	Not too bad
My reading of the poem was			
My knowledge about tastes is			
The growth of my food vocabulary is			
My work in planning group work was			
Other:			

■ b) Compare your self-evaluation with a partner's. Talk about it!



Chief Editor
Web Editor



Game Editor



Resource Editor



Picture Editor



Fun Editor



Editor

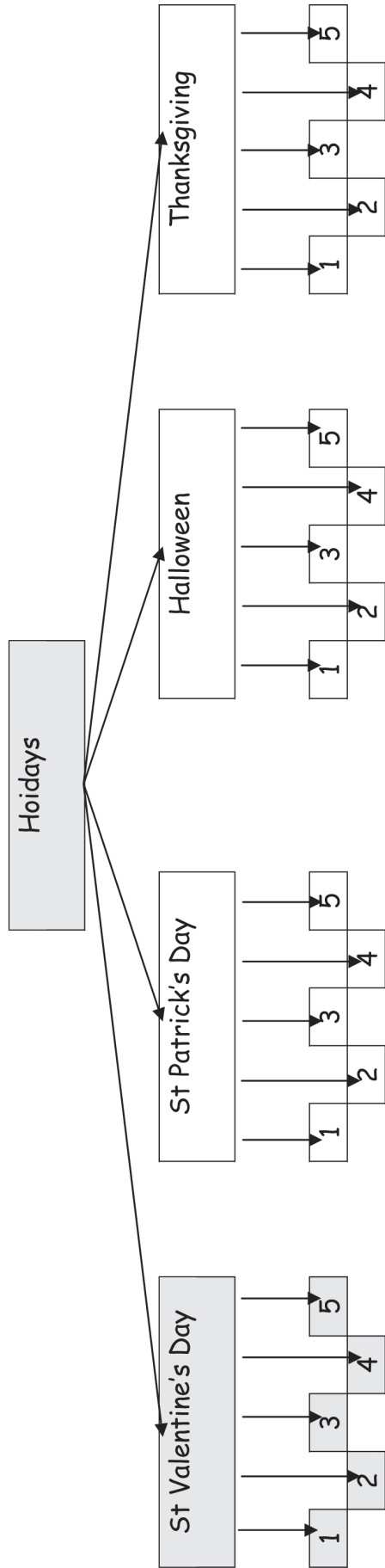

1. History of the holiday

2. Images

3. Games

4. Extras

5. Top 10 Links

Valentine's Day: Worksheet

Grey parts have been done to provide a scheme.

Named folders have been created. Grey parts and named folders make up the (3.4) Holidays Webpage Skeleton
 Numbered white parts and connections should be done.

TASK 1 – BASIC PRINCIPLES OF BUILDING YOUR OWN HOLIDAY WEBPAGE –
GROUP DISCUSSION

■ Have a look at the *Holidays Webpage Skeleton* and discuss in your group how to build your part. Look at the sub-pages of the Valentine's Day one by one, read the expectations in the right column, and identify them in the Valentine's pages. Your web page will be evaluated on the basis of these expectations!

How many HTML pages belong to a holiday?	5
Colours, fonts, tables and alignment	Colours and fonts can be different, but the basic structure must be the same. Use tables where the pattern does. Align them centred.
Navigation	There are links to each sub-page and the main page on all pages.
History sub-page	Create your own web page using the history resources, but simplify the information. Give the links of the original resources. Add a picture.
Images sub-page	Put the images in a table, delete the HTML links (right click on the pictures), and give all the sources. Do not use images if you are uncertain about their free access (it should be declared on their homepages).
Games sub-page	Choose some online games that help learning English and some that are just for fun. Make the difference obvious. Explain what you can find behind each link. Include a picture on the page.
Extras sub-page	Make some holiday-related music available (by links only), explain what there is behind the links. You can also include some jokes or other fun, but do not forget to give the reference. Include a picture.
Top 10 Links sub-page	Put the list of the 10 best links together when all the other pages are completed and you really know what the top 10 links are. Explain the content. Include a picture.

Some links to start with:

Caboose Free St Patrick Clipart for kids (close the ads, go down the page): <http://www.kidsdomain.com/holiday/patrick/clip.html>

Quizzes and other stuff

<http://www.caslt.org/research/stpatrick.htm>

Trivia Hunt

<http://arthur.k12.il.us/arthurgs/stpthunt.htm>

Video, interactive games etc.

<http://www.ac-nancy-metz.fr/enseign/anglais/Henry/patrick.htm#voc>

The History Channel on St Patrick, including video

<http://www.historychannel.com/exhibits/stpatricksday/index.jsp?page=video>

TASK 2

■ **Collect the resources you need**

If you have more than needed, get together and choose the best ones to use.

Page	Name and URL of the resource (copy paste), also the file names of the pictures that you have saved in your folder
History	
Images	
Games	
Extras	
Top 10 Links	

TASK 3

■ Create the sub-pages one by one

Use this checklist!

No		Done
1	Find the folder named 'St Patrick' in the 'Holiday' folder. All the materials should be put there. The digital format of this worksheet is also available within the 'St Patrick' folder.	
2	Open 5 new pages in Netscape Composer and save them as history_SP.html, images_SP.html, games_SP.html, extras_SP.html, bestlinks_SP.html	
3	Fill in the 'Page title and properties' in the 'Format' menu (top of the screen). Save changes.	
4	Choose 'Page colour and properties' in the same menu and set it.	
5	Write the title in the middle; choose a font type and size (for all the pages of the holiday!). Save changes.	
6	See the pattern (the corresponding page of Valentine's Day) and create a table if necessary, use the 'Insert' menu. (choose the colours, write the text, take care of font size, colours and alignment – 'Format' menu). Save changes.	
7	Create links where needed ('Link' menu). When using a saved file take care of using relative links. URLs must be copy-pasted. Save changes.	
8	Insert the images you want to use. (They must be in the same folder) Change the size if needed ('Format' menu, 'Image properties') Save changes.	
9	Open your page in Netscape Navigator ('File' menu, 'Open', 'Choose file') and check if it works	
10	Correct whatever needs to be corrected. Save changes.	
11	Compare your page to the Valentine pattern. Correct whatever needs to be corrected. Save changes.	
12	Check the job with someone from the group. Make the necessary changes and save them.	

TASK 4 – REHEARSAL

■ Each group checks another website. All the members check the sub-page that they themselves have created about another holiday.

(Fun Editors check the job of Fun Editors.)

■ a) Look at the criteria in Task 1 and the Checklist in Task 3 and tick if the web page is

Very good

Good

Quite Good

Needs basic improvements

b) List the concrete problems to be corrected
(E.g.: Texts for links to other pages are missing)

1 _____

2 _____

3 _____

4 _____

5 _____

6 _____

7 _____

8 _____

9 _____

10 _____

■ c) Go back to your own page with the evaluation and make the necessary corrections.

TASK 5 – PUTTING THE ST PATRICK PAGES TOGETHER AND LINKING THEM TO THE HOLIDAY HOMEPAGE

- ✓ Put all files of the holiday into a single folder (images, html pages, everything you have used or created), otherwise the website will not work. (Web Editor)
- ✓ Link the St Patrick sub-pages to each other. (Web Editor)
- ✓ Put all files of all 4 holidays into the Website Skeleton folder (images, html pages, everything you have used or created), otherwise the website will not work. (3 Web Editors)
- ✓ Link all the Holiday pages to the home of the Holidays Website. (3 Web Editors together)
- ✓ Check if it works all right. (3 Web Editors together)
- ✓ Upload the whole Holiday website to the School Website. (System Administrator + Chief Web Editor)

TASK 1 – BASIC PRINCIPLES OF BUILDING YOUR OWN HOLIDAY WEBPAGE –
GROUP DISCUSSION

■ Have a look at the *Holidays Webpage Skeleton* and discuss in your group how to build your part. Look at the sub-pages of Valentine's Day one by one, read the expectations in the right column, and identify them in the Valentine's pages. Your web page will be evaluated on the basis of these expectations!

How many HTML pages belong to a holiday?	5
Colours, fonts, tables and alignment	Colours and fonts can be different, but the basic structure must be the same. Use tables where the pattern does. Align them centred.
Navigation	There are links to each sub-page and the main page on all pages.
History sub-page	Create your own web page using the history resources but simplify the information. Give the links of the original resources. Add a picture.
Images sub-page	Put the images in a table, delete the HTML links (right click on the pictures), and give all the resources. Do not use images if you are uncertain about their free access (it should be declared on their homepages).
Games sub-page	Choose some online games that help learning English and some that are just for fun. Make the difference obvious. Explain what you can find behind each link. Include a picture on the page.
Extras sub-page	Make some holiday-related music available (by links only), explain what there is behind the links. You can also include some jokes or other fun, but do not forget to give the reference. Include a picture.
Top 10 Links sub-page	Put the list of the 10 best links together when all the other pages are completed and you really know what the top 10 links are. Explain the content. Include a picture.

Some links to start with:

Caboose Free Halloween Clipart for kids (close the ads, go down the page): <http://www.kidsdomain.com/holiday/halloween/clipart/1clip1.html>

Quizzes and other stuff

<http://www.caslt.org/research/halloween.htm>

Video, interactive games etc.

<http://www.ac-nancy-metz.fr/enseign/anglais/Henry/hallo.htm>

The History Channel on Halloween, including video

<http://www.historychannel.com/exhibits/halloween/>

TASK 2

■ Collect the resources you need

If you have more than needed, get together and choose the best ones to use.

Page	Name and URL of the resource(copy paste), also the file names of the pictures that you have saved in your folder
History	
Images	
Games	
Extras	
Top 10 Links	

TASK 3

■ Create the sub pages one by one

Use this checklist!

No		Done
1	Find the folder named 'Halloween' in the 'Holiday' folder. All the materials should be put there. The digital format of this worksheet is also available within the 'Halloween' folder.	
2	Open 5 new pages in Netscape Composer and save them as history_hallo.html, images_hallo.html, games_hallo.html, extras_hallo.html, bestlinks_hallo.html	
3	Fill in the 'Page title and properties' in the 'Format' menu (top of the screen). Save changes.	
4	Choose 'Page colour and properties' in the same menu and set it.	
5	Write the title in the middle; choose a font type and size (for all the pages of the holiday!). Save changes.	
6	See the pattern (the corresponding page of Valentine's Day) and create a table if necessary, use the 'Insert' menu. (choose the colours, write the text, take care of font size, colours and alignment - 'Format' menu) Save changes.	
7	Create links where needed ('Link' menu), when using a saved file take care of using relative links. URLs must be copy-pasted. Save changes.	
8	Insert the images you want to use. (They must be in the same folder) Change the size if needed ("Format' menu, 'Image properties') Save changes.	
9	Open your page in Netscape Navigator ('File' menu, 'Open', 'Choose file') and check if it works	
10	Correct whatever needs to be corrected. Save changes.	
11	Compare your page to the Valentine pattern. Correct whatever needs to be corrected. Save changes.	
12	Check the job with someone from the group. Make the necessary changes and save them.	

TASK 4 – REHEARSAL

■ Each group checks another website. All the members check the sub-page that they themselves have created about another holiday. (Fun Editors check the job of Fun Editors.)

■ a) Look at the criteria in Task 1 and the Checklist in Task 3 and tick if the web page is

Very good Good Quite Good Needs basic improvements

■ b) List the concrete problems to be corrected (E.g.: Texts for links to other pages are missing)

- 1 _____
- 2 _____
- 3 _____
- 4 _____
- 5 _____
- 6 _____
- 7 _____
- 8 _____
- 9 _____
- 10 _____

■ c) Go back to your own page with the evaluation and make the necessary corrections.

TASK 5 PUTTING THE HALLOWEEN PAGES TOGETHER AND LINKING THEM TO THE HOLIDAY HOMEPAGE

- Put all files of the holiday into a single folder (images, html pages, everything you have used or created), otherwise the website will not work. (Web Editor)
- Link the Halloween sub pages to each other. (Web Editor)
- Put all files of all 4 holidays into the Website Skeleton folder (images, html pages, everything you have used or created), otherwise the website will not work. (3 Web Editors)

- Link all the Holiday pages to the home of the Holidays Website.
(3 Web Editors together)
- Check if it works all right. (3 Web Editors together)
- Upload the whole Holiday website to the School Website.
(System Administrator + Chief Web Editor)

TASK 1 – BASIC PRINCIPLES OF BUILDING YOUR OWN HOLIDAY WEBPAGE –
GROUP DISCUSSION

■ Have a look at the *Holidays Webpage Skeleton* and discuss in your group how to build your part. Look at the sub-pages of Valentine's Day one by one, read the expectations in the right column, and identify them in the Valentine's pages. Your web page will be evaluated on the basis of these expectations!

How many HTML pages belong to a holiday?	5
Colours, fonts, tables and alignment	Colours and fonts, can be different but the basic structure must be the same. Use tables where the pattern does. Align them centred.
Navigation	There are links to each sub-page and the main page on all pages.
History sub-page	Create your own web page using the history resources but simplify the information. Give the links of the original resources. Add a picture.
Images sub-page	Put the images in a table, delete the HTML links (right click on the pictures), and give all the resources. Do not use images if you are uncertain about their free access (it should be declared on their homepages).
Games sub-page	Choose some online games that help learning English and some that are just for fun. Make the difference obvious. Explain what you can find behind each link. Include a picture on the page.
Extras sub-page	Make some holiday-related music available (by links only), explain what there is behind the links. You can also include some jokes or other fun, but do not forget to give the reference. Include a picture.
Top 10 Links sub-page	Put the list of the 10 best links together when all the other pages are completed and you really know what the top 10 links are. Explain the content. Include a picture.

Some links to start with:

Caboose Free Thanksgiving Clipart for kids ((close the ads, go down the page) <http://www.kidsdomain.com/holiday/thanksgiving/clipart/1clip1.html>

Quizzes and other stuff

<http://www.caslt.org/research/Thanksgiving.htm>

Video, interactive games etc.

<http://www.ac-nancy-metz.fr/enseign/anglais/Henry/thanks.htm>

The History Channel on Thanksgiving, including video

<http://www.historychannel.com/thanksgiving/>

TASK 2

■ Collect the resources you need

If you have more than needed, get together and choose the best ones to use.

Page	Name and URL of the resource(copy paste), also the file names of the pictures that you have saved in your folder
History	
Images	
Games	
Extras	
Top 10 Links	

TASK 3

■ Create the sub pages one by one

Use this checklist!

No		Done
1	Find the folder named 'Thanksgiving' in the 'Holiday' folder. All the materials should be put there. The digital format of this worksheet is also available within the 'Thanksgiving' folder.	
2	Open 5 new pages in Netscape Composer and save them as history_thanks.html, images_thanks.html, games_thanks.html, extras_thanks.html, bestlinks_thanks.html	
3	Fill in the 'Page title and properties' in the 'Format' menu (top of the screen). Save changes.	
4	Choose 'Page colour and properties' in the same menu and set it.	
5	Write the title in the middle; choose a font type and size (for all the pages of the holiday!). Save changes.	
6	See the pattern (the corresponding page of Valentine's Day) and create a table if necessary, use the 'Insert' menu. (choose the colours, write the text, take care of font size, colours and alignment - 'Format' menu) Save changes.	
7	Create links where needed ('Link' menu), when using a saved file take care of using relative links. URLs must be copy-pasted. Save changes.	
8	Insert the images you want to use. (They must be in the same folder) Change the size if needed ("Format' menu, 'Image properties') Save changes.	
9	Open your page in Netscape Navigator ('File' menu, 'Open', 'Choose file') and check if it works	
10	Correct whatever needs to be corrected. Save changes.	
11	Compare your page to the Valentine pattern. Correct whatever needs to be corrected. Save changes.	
12	Check the job with someone from the group. Make the necessary changes and save them.	

TASK 4 – REHEARSAL

■ Each group checks another website. All the members check the sub-page that they themselves have created about another holiday. (Fun Editors check the job of Fun Editors.)

■ a) Look at the criteria in Task 1 and the Checklist in Task 3 and tick if the web page is

Very good Good Quite Good Needs basic improvements

■ b) List the concrete problems to be corrected (E.g.: Texts for links to other pages are missing)

- 1 _____
- 2 _____
- 3 _____
- 4 _____
- 5 _____
- 6 _____
- 7 _____
- 8 _____
- 9 _____
- 10 _____

■ c) Go back to your own page with the evaluation and make the necessary corrections.

TASK 5 – PUTTING THE THANKSGIVING PAGES TOGETHER AND LINKING THEM TO THE HOLIDAY HOMEPAGE

- Put all files of the holiday into a single folder (images, html pages, everything you have used or created), otherwise the website will not work. (Web Editor)
- Link the Thanksgiving sub pages to each other. (Web Editor)
- Put all files of all 4 holidays into the Website Skeleton folder (images, html pages, everything you have used or created), otherwise the website will not work. (3 Web Editors)

- Link all the Holiday pages to the home of the Holidays Website.
(3 Web Editors together)
- Check if it works all right. (3 Web Editors together)
- Upload the whole Holiday website to the School Website.
(System Administrator + Chief Web Editor)

TASK 1 – IDENTIFICATION

■ Tick the holiday you will explore! Name all of them. Do you remember the dates?

		
Date: _____	Date: _____	Date: _____

TASK 2 – THE HISTORY OF THE DAY

■ Read the history of the holiday in the website and list 5 important or interesting facts.

- 1 _____
- 2 _____
- 3 _____
- 4 _____
- 5 _____

TASK 3 – PLAYTIME

■ Try some of the games related to the holiday, given in the website. Choose the best one.

Name/title of the game: _____

URL: _____

What can you do there? Explain it in 3-4 sentences. _____

TASK 3 – IMAGES

- Chose the best one, copy-paste it here:

TASK 4 – TRY SOME EXTRAS AND TOP LINKS

- Choose a link or an extra activity and introduce it to someone who has not seen it:

TASK 5 – PRINT YOUR WORKSHEET

- Check the format of your worksheet. It must not be more than 2 pages. Print your worksheet if possible. If not, e-mail it to your teacher.

TASK 6 – WHAT HAVE YOU DONE? - DISCUSSION

- Get together with your holiday focus group and have a chat about your explorations. Use your notes and ask each others questions, like '*What have you done?*' '*What have you seen?*' '*What did you find out about the holiday?*', etc.

